

APPLICATION INFORMATION

*The G5A is a High Altitude version of the G55. All information provided is applicable to both the G55 & G5A Series pumps unless otherwise specified.

Flojet's G55 & G5A Series pumps are designed for dispensing Bag-In-Box (BIB) syrups, juice concentrates (without pulp or particulate), teas, wines, draught beer and liquor.

A pump can supply up to eight (8) 3.0 oz./sec. valves or four (4) 4.5 oz./sec. valves from a remote location.

INSTALLATION

MOUNTING

- Pump must be located within 10 ft. (3.05m) above or below bag-in-box.
- Pump must be facing down to maximize pump performance.
- Mounting grommets are part of pump assembly, and add stability.
- Fasten pump securely to BIB rack using #10 sheet metal screws or use wood screws for wall mounting. (Screws not included with pump)

HOSE CONNECTIONS

- All fittings are quick change.
- Be sure the brass CO₂ fitting is installed all the way and the retainer clip is engaged.
- For product hose use food grade vinyl hose or equivalent to Tygon hose.
- Secure with appropriate Oetiker Clamp for specified tubing size or worm gear clamp 360 uniform clamping band.
- Both ends of product out hose should be secured. One end to the product out port and the other end to the dispensing valve.
- It is advisable to secure all hoses to prevent excessive movement.
- If pump is installed in an enclosed area such as a closet or basement, connection of a hose to the gas discharge fitting should be done to vent CO₂ to atmosphere safely. The muffler portion of the CO₂ exhaust can be removed with pliers.
- The CO₂ exhaust fitting may be removed when the air pressure is released to empty pump of condensation when using an air compressor.

Pump Symbols

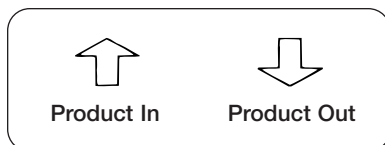

DIMENSIONAL DRAWING

Inches (Millimeters)

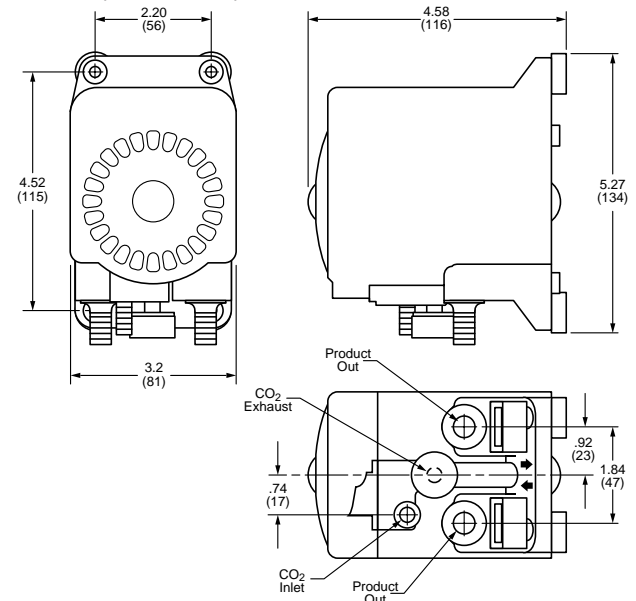

Model G55 & G5A CO₂ / Air Driven

Specifications

Pump DesignPositive Displacement, Double Diaphragm
Power Source CO₂ Gas, Nitrogen or Compressed Dry Filtered Air
Materials of Construction (wetted parts).....Polypropylene, Santoprene®, EPDM, AISI 303 or 304 Stainless Steel
Temperature Limits34° - 120° F (1.1° - 49° C)
Weight1.24 lbs. (0.56 kg.)
Dimensions5.27" H x 3.21" W x 4.58" D (133.8 mm x 81.5 mm x 116.3 mm)
Displacement3.2 oz. per cycle
Self PrimingUp to 10 ft. (3.05 m)
Operating Pressure.....20 psi (1.4 bar) min./90 psi (6.2 bar) max.
Liquid Inlet Pressure30 psi (2.1 bar) max.
Flow Rate7.0 oz. (207.0 ml)/sec. - Open Flow
Noise Level.....Maximum 80 dB
ApprovalsNSF listed, SK & CE

AVAILABLE PORT FITTINGS

Gas Inlet:

- 1/4" (6.3mm) Barb, plastic, straight
- 1/4" (6.3mm) Barb, brass w/CO₂ shut-off - straight, tee or elbow.
- John Guest for 1/4" O.D. tubing, plastic or brass w/CO₂ shut-off

Gas Outlet:

- 1/4" (6.3mm) Barb, plastic, straight

Product Inlet & Outlet:

- 1/4" (6.3mm) Barb, stainless steel, straight or elbow
- 3/8" (9.5mm) Barb, plastic, straight
- 3/8" (9.5mm) Barb, stainless steel, straight or elbow
- 1/2" (12.7mm) Barb, stainless steel, straight
- John Guest for 1/4" or 3/8" O.D. tubing, plastic

OPERATION

To start operation, regulate gas pressure to desired setting. For most installations, 65 PSI (4.5 BAR) will be adequate. (To determine gas pressure requirements refer to Flojet's G55 Series Pumps – Run/Rise Charts.) Open dispensing valve to purge air from system. Once primed, pump will operate automatically by starting and stopping on demand, as beverage is served. Product flow and pressure can be adjusted by increasing or decreasing gas pressure to accommodate varying product viscosity, temperature, syrup flow rates, inside diameter of tubing and fittings as well as horizontal and vertical distance of outlet tubing.

The G55 pump is capable of handling up to 30 PSI (2.1 BAR) product inlet pressure. This is excellent for boosting syrup applications. **CAUTION: Do not exceed 90 PSI (6.2 BAR) total gas inlet pressure for both pumps.**

The Flojet G55 Series Pump has a built-in auto shutoff valve which stops the pump by shutting off the gas supply when the bag is empty. The auto shutoff will automatically restart the pump when a new bag is connected.

The Model G55 can be used in series. The first pump pumping from location (X) to second pump (Y). The pump can handle 30 PSI (2.1 BAR) liquid inlet pressure. The second pump should be set using the run rise requirements. In a static condition the dispensing valve will see the accumulated pressure from both pumps. 3/8" (9.5 mm) tubing is required in syrup boosting applications.

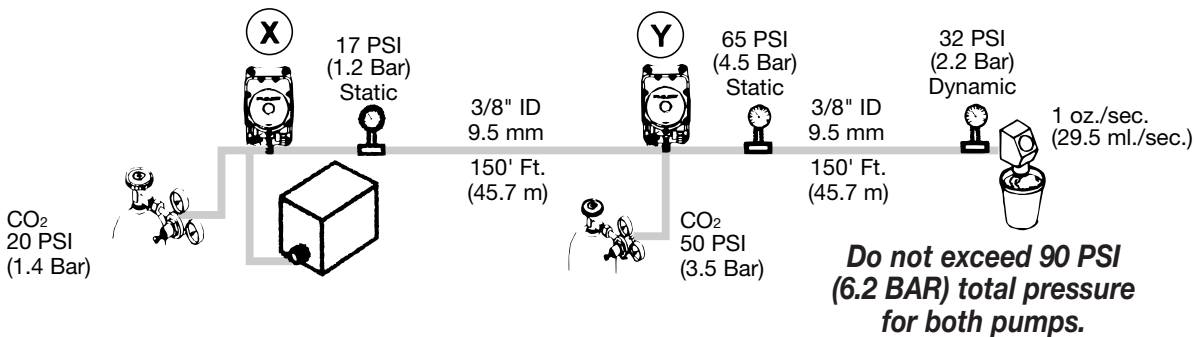

WARRANTY

FLOJET warrants this product to be free of defects in material and/or workmanship for a period of five (5) years after purchase by the customer from FLOJET. During this five (5) year warranty period, FLOJET will at its option, at no charge to the customer, repair or replace this product if found defective, with a new or reconditioned product, but not to include costs of removal or installation. No product will be accepted for return without expressed authorization. All returned goods must be shipped with transportation charges prepaid. This is only a summary of our Limited Warranty. For a copy of our complete warranty, please request Form No. F100-248.

Flojet



U.S.A.
Flojet
20 Icon
Foothill Ranch, CA 92610-3000
Tel: (949) 859-4945
Fax: (949) 859-1153

UNITED KINGDOM
Flojet, Unit 1, Avant Business Centre
Denbigh West Industrial Estate
Milton Keynes, Bucks, England MK1 1DL
Tel: 44 1908 370088
Fax: 44 1908 373731

Typical Bag-In-Box Installation

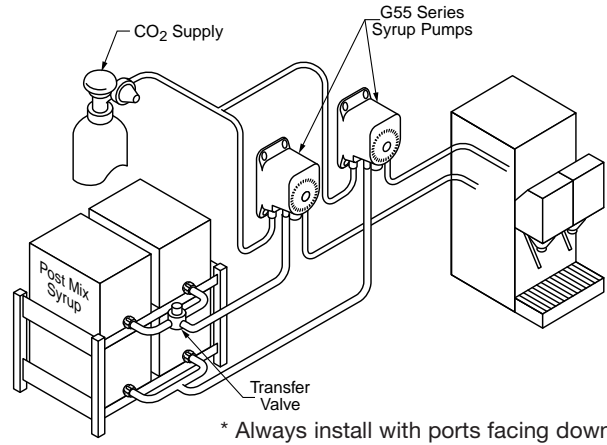

The diagram above shows a "typical Bag-in-Box installation" with a single bag connection and a multiple bag connection with a Flojet Transfer Valve assembly. Flojet Part Nos. 1500-030 and 1500-130 transfer valves are recommended for automatic unattended change-over from empty to full bag for all G55 pumps. For High Altitude installations (above 3000 ft.) use the G5A Series pumps with Flojet Part Nos. 1500-031 and 1500-131 transfer valves



WARNING



IF USED WITH CO₂ OR N₂ BE SURE THE AREA IS WELL VENTILATED

ONLY USE PUMPS WITH SPECIFIED PRODUCTS. DO NOT PUMP FLAMMABLE LIQUIDS OR USE WHERE FLAMMABLE VAPORS ARE PRESENT